

ZF5HP19

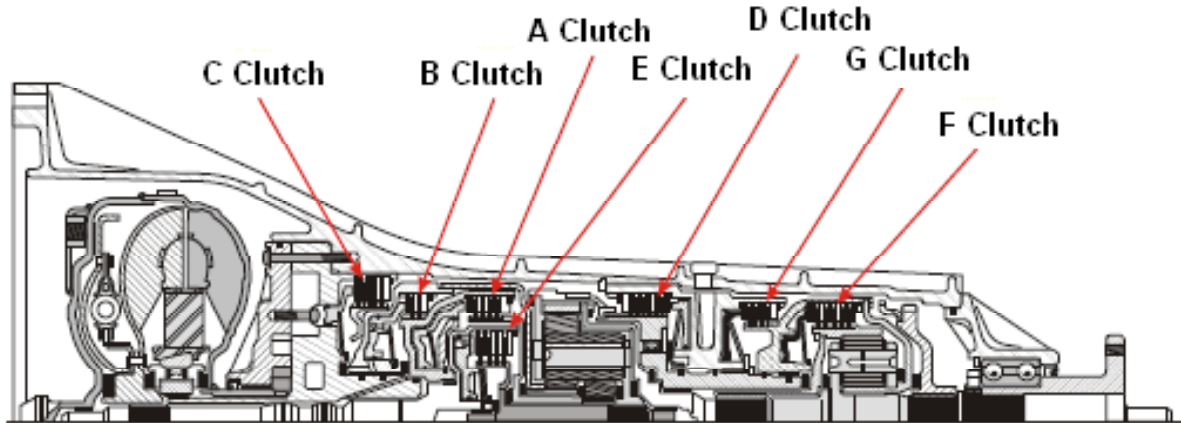

Range	A Clutch	B Clutch	C Clutch	D Clutch	Low Sprag	E Clutch	F Clutch	G Clutch
Park								X
Reverse		X		X				X
Neutral								X
D - 1st	X				Holding			X
D - 2nd	X		X					X
D - 3rd	X		X				X	
D - 4th	X					X	X	
D - 5th			X			X	X	
4	X					X	X	
3	X		X				X	
2	X		X					X

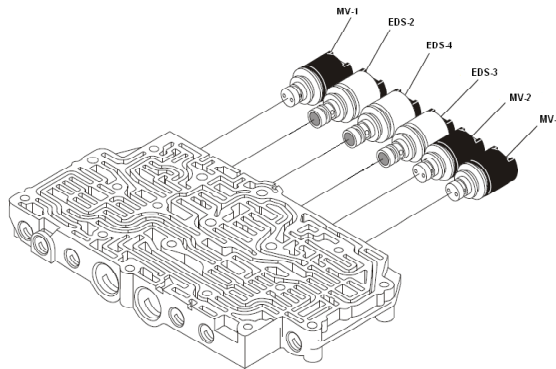

Range	MV-1	MV-2	MV-3	EDS-1	EDS-2	EDS-3	EDS-4
Park	ON			xx			
Reverse	ON		X	xx		#	
Neutral	ON	ON		xx		#	
D - 1st	ON	ON		xx		#	
D - 2nd	ON	ON		xx	#	#	
D - 3rd		ON		xx	#		(#)
D - 4th				xx			(#)
D - 5th			(x)	xx	#		(#)
Default	OFF	OFF	OFF	OFF	OFF	OFF	OFF

X	On if reverse selected at high speed to inhibit reverse
(x)	Off pressure low On pressure High
xx	Line pressure control (PWM) Off pressure high On pressure Low
#	(PWM) Off pressure low On pressure high
(#)	TCC apply dependant on road speed and throttle position